

注意：

允許學生個人、非營利性的圖書館或公立學校合理使用本基金會網站所提供之各項試題及其解答。可直接下載而不須申請。

重版、系統地複製或大量重製這些資料的任何部分，必須獲得財團法人臺北市九章數學教育基金會的授權許可。

申請此項授權請電郵 ccmp@seed.net.tw

Notice:

Individual students, nonprofit libraries, or schools are permitted to make fair use of the papers and its solutions. Republication, systematic copying, or multiple reproduction of any part of this material is permitted only under license from the Chiuchang Mathematics Foundation.

Requests for such permission should be made by e-mailing Mr. Wen-Hsien SUN ccmp@seed.net.tw

Solution to Fifth International Mathematics Assessment for Schools Round 1 of Upper Division

1. Which of the following expression is incorrect?

- (A) $29 + 92 = (2 + 9) \times (9 + 2)$ (B) $47 + 74 = (4 + 7) \times (7 + 4)$
 (C) $36 + 63 = (3 + 6) \times (6 + 3)$ (D) $56 + 65 = (5 + 6) \times (6 + 5)$
 (E) $38 + 83 = (3 + 8) \times (8 + 3)$

【Solution】

Each of (A), (B), (D) and (E) states that $11 \times 11 = 121$. Since $36 + 63 \neq 9 \times 9$, (C) is incorrect.

Answer : (C)

2. Each of P, Q and R writes down an integer greater than 2015. When 2013 is subtracted from P's number, 2014 is subtracted from Q's number and 2015 is subtracted from R's number, the product of the differences is 88407. Which of the following statements is correct?

- (A) P's and Q's numbers are odd and R's is even.
 (B) Q's and R's numbers are odd and P's is even.
 (C) R's and P's numbers are odd and Q's is even.
 (D) All three numbers are odd.
 (E) Q's number is odd and R's and P's numbers are even.

【Solution】

Since the product is odd, all three differences are odd. Hence (E) is correct.

Answer : (E)

3. Which of the following figures has area closest to 1?

(A)

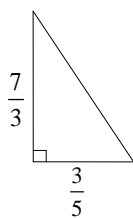

(B)

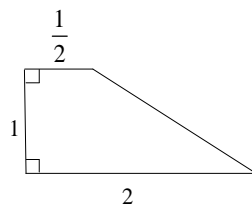

(C)

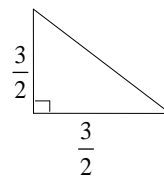

(D)

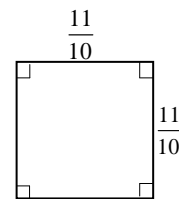

(E)

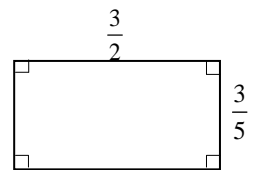

【Solution】

The area of figure (A) is $\frac{1}{2} \times \frac{7}{3} \times \frac{3}{5} = \frac{7}{10}$, that is $\frac{3}{10}$ different with 1;

The area of figure (B) is $\frac{1}{2} \times (\frac{1}{2} + 2) \times 1 = \frac{5}{4}$, that is $\frac{1}{4}$ different with 1;

The area of figure (C) is $\frac{1}{2} \times \frac{3}{2} \times \frac{3}{2} = \frac{9}{8}$, that is $\frac{1}{8}$ different with 1;

The area of figure (D) is $\frac{11}{10} \times \frac{11}{10} = \frac{121}{100}$, that is $\frac{21}{100}$ different with 1;

The area of figure (E) is $\frac{3}{2} \times \frac{3}{5} = \frac{9}{10}$, that is $\frac{1}{10}$ different with 1.

Since $\frac{3}{10} = \frac{60}{200} > \frac{1}{4} = \frac{50}{200} > \frac{21}{100} = \frac{42}{200} > \frac{1}{8} = \frac{25}{200} > \frac{1}{10} = \frac{20}{200}$, hence the closest is (E).

Answer : (E)

4. The numerator of a fraction is reduced by 25% and the denominator is increased by 25%. By which of the following numbers can we multiply the original fraction to obtain the new fraction?

- (A) $\frac{1}{2}$ (B) $\frac{1}{4}$ (C) $\frac{3}{4}$ (D) $\frac{3}{5}$ (E) 1

【Solution】

The change in the numerator reduces the fraction to $\frac{3}{4}$ of it. The change in denominator reduces the fraction to $\frac{4}{5}$ of it. Since $\frac{3}{4} \times \frac{4}{5} = \frac{3}{5}$, the correct choice is (D).

Answer : (D)

5. Sixteen points are arranged in a 3 cm by 3 cm formation. Four of them are removed, leaving behind twelve points as shown in the diagram. If we choose three of these twelve points as vertices of a triangle, what is the largest possible area of this triangle, in cm^2 ?

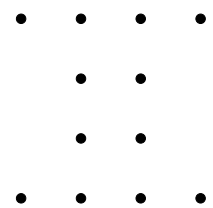

- (A) 9 (B) $\frac{9}{2}$ (C) 3 (D) 2 (E) $\frac{3}{2}$

【Solution】

It is clear that we should not choose any of the four central points. Then two of the vertices are in the same row while the third one is in the opposite row. The height is 3 cm and the largest possible base is also 3 cm. Hence the largest possible area of this triangle is $\frac{1}{2} \times 3 \times 3 = \frac{9}{2} \text{ cm}^2$, the correct choice is (B).

Answer : (B)

6. From one-third of a positive integer, one-quarter of the next integer is subtracted. If the difference is 2, what is the sum of the two integers?

- (A) 31 (B) 45 (C) 55 (D) 79 (E) 103

【Solution】

The amount subtracted is one-fourth of the smaller integer plus $\frac{1}{4}$. Hence $\frac{1}{3} - \frac{1}{4} = \frac{1}{12}$ of the smaller integer is equal to $2 + \frac{1}{4} = \frac{9}{4}$. Hence the smaller integer is $\frac{9}{4} \div \frac{1}{12} = 27$, and $27 + 28 = 55$. Hence the correct choice is (C).

Answer : (C)

7. The diagram below is the seating plan of a cinema. How many blocks of three adjacent seats are unshaded, not counting those in the first row?

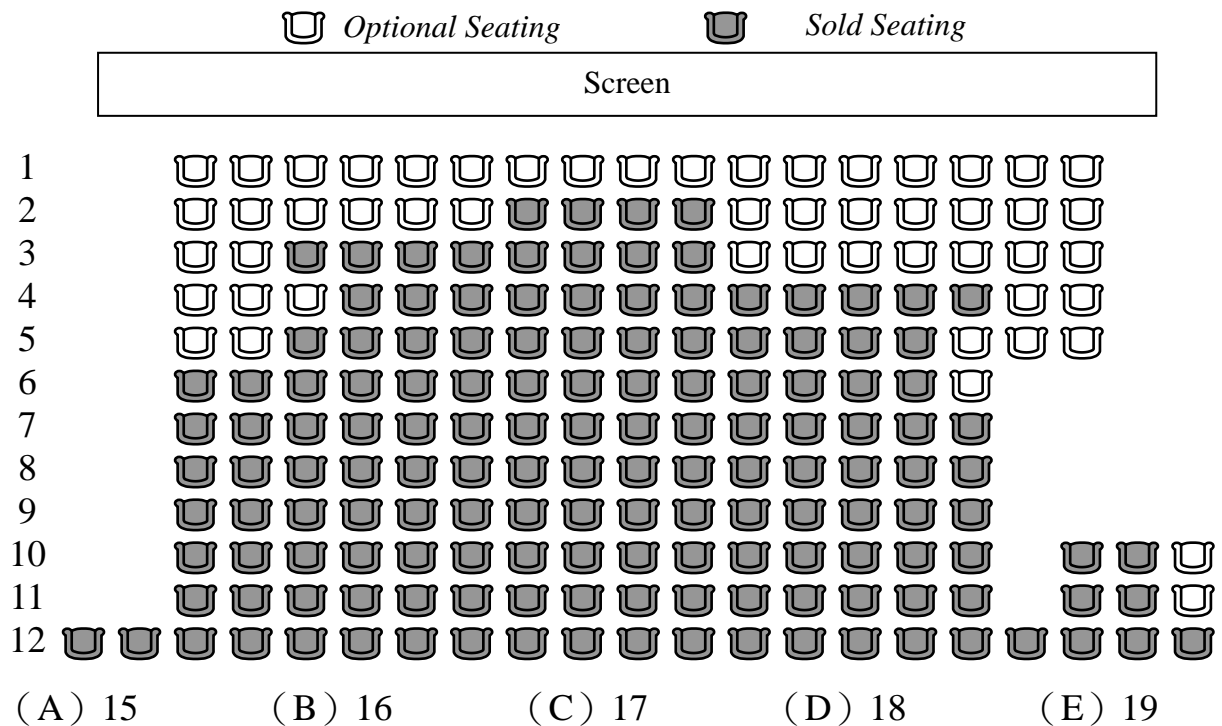

【Solution】

Among the available seats, there are two blocks of length 3, one block of length 6 and two block of length 7. The total number of ways is given by $2 \times ((3-2) + (7-2)) + (6-2) = 16$. The correct choice is (B).

Answer : (B)

8. In an amusement park, each ride on the Bumper Cars costs 10 dollars, each ride on the Pirate Boat costs 15 dollars and each ride on the Roller Coaster costs 20 dollars. If Waldo spends 110 dollars in total on at least one ride of each kind, how many times has he taken a ride on the Roller Coaster?

(A) 1 (B) 2 (C) 3 (D) 4 (E) 5

【Solution】

Since we wish to maximize the number of rides on the Roller Coaster, we minimize the numbers of rides of the other two kinds. Note that since 110 is even, Waldo must have ridden Bumper Cars once and the Pirate Ship twice. The total cost is $10 + 2 \times 15 = 40$ dollars, and $110 - 40 = 70$ dollars are enough for 3 rides on the Roller Coaster, with 10 dollars left over for another ride on Bumper Cars. The correct choice is (C).

Answer : (C)

9. The first term of a sequence is 2. Each subsequent term is the remainder when 3 times the preceding term is divided by 5. Thus the second term is 1, the remainder when $3 \times 2 = 6$ is divided by 5. How many of the first 2015 terms of this sequence are equal to 1?

(A) 403 (B) 504 (C) 672 (D) 1008 (E) 2014

【Solution】

The sequence is periodic with the repeating block (2, 1, 3, 4). The number of complete blocks up to 2015 is 503 since $2015 = 4 \times 503 + 3$. Since there is a 1 in the incomplete block, the total is $503 + 1 = 504$. The correct choice is (B).

Answer : (B)

10. A cubic box of side length 15 cm has two holes. One of them is 5 cm above and 5 cm to the left of the bottom right corner of the front face. The other is 5 cm below and 5 cm to the left of the top right corner of the right face. The size of the holes and the thickness of the box are negligible. If the box is filled with water and one of its faces rests on a horizontal surface, some water will leak out through the holes. What is the maximum amount, in cm^3 , of water that can remain inside the box?

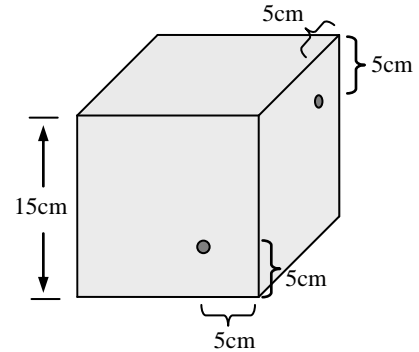

- (A) 1000 (B) 1125 (C) 1500 (D) 2250 (E) 3375

【Solution】

To maximize the distance between the lower hole and the table, the box should rest of the left face. Then the box can hold an amount of water equal to $15 \times 15 \times (15 - 5) = 2250 \text{cm}^3$. The correct choice is (D).

Answer : (D)

11. How many prime numbers less than 50 is 1 more than the product of two distinct prime numbers each less than 50?

- (A) 2 (B) 3 (C) 4 (D) 5 (E) 6

【Solution】

Since the product is even, the smaller of the two prime factors is 2. Possible products less than 50 are 6, 10, 14, 22, 26, 34, 38 and 46, but 15, 27, 35 and 39 are not prime numbers. The correct choice is (C).

Answer : (C)

12. Goldie has two identical gold coins and Sylvia has three identical silver coins. The total weight of Goldie's coins is equal to the total weight of Sylvia's coins. If they trade one coin with each other, then the total weight of Goldie's coins is 12 grams less than the total weight of Sylvia's coins. What is the weight, in grams, of each gold coin?

- (A) 12 (B) 15 (C) 18 (D) 21 (E) 24

【Solution】

After the trade, Sylvia has one more silver coin than Goldie. Hence its weight is 12 grams. The total weight of two gold coins is equal to the total weight of three silver coins, which is 36 grams. The correct choice is (C).

Answer : (C)

13. Jasmine tea sells for 320 dollars per kg while Oolong tea sells for 480 dollars per kg. A mixture consisting of 3 parts of Jasmine tea to 5 parts of Oolong tea sells for 450 dollars per kg. What is the maximum amount, in dollars, for which 10 kg of each of Jasmine tea and Oolong tea may be sold?

- (A) 8000 (B) 8080 (C) 8400 (D) 8480 (E) 9000

【Solution】

If we do not mix, the total amount is $10 \times (320 + 480) = 8000$ dollars. When 1 kg of the mixture is separated into its component parts and sold separately, the price is $(3 \times 320 + 5 \times 480) \div 8 = 420$ dollars, 30 dollars less than the price of the mixture.

Thus we should mix as much as we can.



Now 6 kg of Jasmine tea can mix with the 10 kg of Oolong tea to yield 16 kg of the mixture. Hence the total amount can be as high as $8000 + 16 \times 30 = 8480$ dollars.

The correct choice is (D).

Answer : (D)

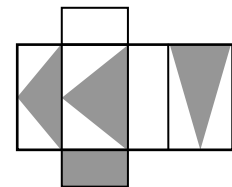
14. Which of the following boxes has a net as shown in the diagram below?

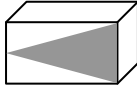
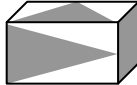
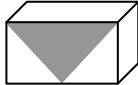

- (A)  (B)  (C)  (D)  (E) 

【Solution】

Rotate (B) about the axis through the centre of the front face, rotate (D) about the axis through the centre of the top face, and rotate (E) about the axis through the centre of the right face. Then the front face and the right faces are as in (A). The top face of each of (A), (D) and (E) is blank, which is wrong. The triangle in the top face of (C) is pointing in the wrong direction. Hence the correct choice is (B).

Answer : (B)

15. The greatest common divisor of a certain positive integer and 315 is 3, and the least common multiple of the same integer and 45 is 360. What is this integer?

- (A) 12 (B) 24 (C) 30 (D) 36 (E) 48

【Solution】

Note that $45 = 3^2 \times 5$, $315 = 3^2 \times 5 \times 7$ and $360 = 2^3 \times 3^2 \times 5$. Hence the only prime factors of our number are 2, 3 and 5. We rule out 3^2 and 5 since the greatest common divisor with 315 is 3. It must be divisible by 2^3 since 45 is not. The correct choice is (B).

Answer : (B)

16. After the fourth test, Kenny's average mark rises by 5 points, but after the fifth test, it drops by 9 points. If his total score in the last two tests is 122 points, how many points does he score in the last test?

- (A) 91 (B) 71 (C) 61 (D) 41 (E) 31

【Solution】

Kenny's score in the fourth test is $5 \times 4 = 20$ points higher than his average in the first three tests. His score in the fifth test is $9 \times 5 = 45$ points lower than his average in the first four tests, and hence 40 points lower than his average in the first three tests. It follows that the difference between his scores in the last two tests is $20 + 40 = 60$ points. Since their sum is 122 points and the score of the last test is lower, it is $(122 - 60) \div 2 = 31$.

Answer : (E)

17. Two paths are to be constructed in a garden 5 m by 5 m and three plans have been submitted. If the amount of space not taken up by the paths is to be as large as possible, which of the following statements is correct?

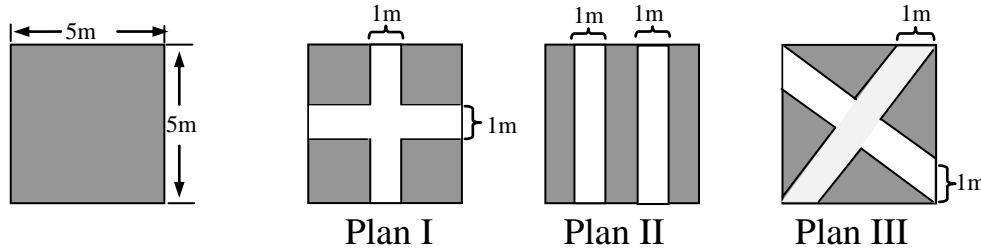

- (A) The non-path area in Plan I is the largest.
- (B) The non-path area in Plan II is the largest.
- (C) The non-path area in Plan III is the largest.
- (D) The non-path areas in all three plans are the same.
- (E) The non-path areas in Plan I and Plan III are the same.

【Solution】

The paths in Plan II do not overlap. The paths in Plan I overlap in a 1 cm by 1 cm square. The perpendicular distances between the parallel sides of the paths in Plan III is less than 1 cm. Hence these paths overlap in a square smaller than 1 cm by 1 cm. The correct choice is (A).

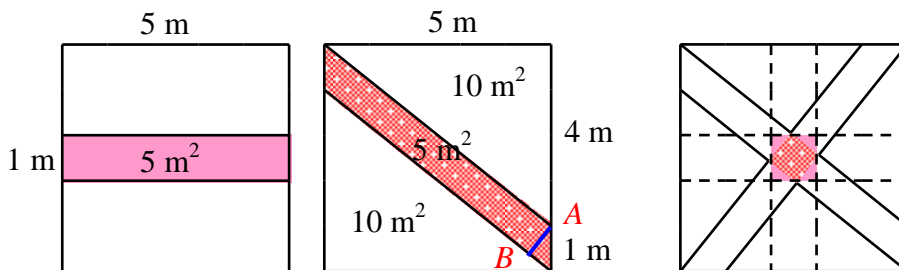

Answer : (A)

18. City B is between City A and City C. William is riding a bike from B to C, a distance of 16 km. After he has gone 6 km, Mary begins to drive a car at 60 km per hour from A to C. If William continues onward, he will reach C at the same time as Mary. If he turns back, he will reach B at the same time as Mary. What is his riding speed, in km per hour?

- (A) 15
- (B) 16
- (C) 18
- (D) 20
- (E) 24

【Solution】

The time William takes to ride the 6 km back to B is equal to the time Mary drives from A to B. Suppose William continues on. When Mary reaches B, William is only $16 - 6 - 6 = 4$ km away from C. Since they reach C together, Mary's driving speed is 4 times William's riding speed. The correct choice is (A).

Answer : (A)

19. The eight symbols 2, 0, 1, 5, I, M, A and S are to be arranged in a row. The digits must precede the letters, and 0 cannot be in the first place. How many such arrangements are there?

- (A) 100 (B) 232 (C) 400 (D) 432 (E) 576

【Solution】

The digits may be placed in $3 \times 3 \times 2 \times 1 = 18$ ways while the letters may be placed in $4 \times 3 \times 2 \times 1 = 24$ ways. Since $18 \times 24 = 432$, the correct choice is (D).

Answer : (D)

20. A hotel has 11 rooms and each staff member has keys to 7 different rooms. For each room, at least two staff members must hold its key. What is the minimum number of staff members the hotel must have?

- (A) 3 (B) 4 (C) 5 (D) 6 (E) 7

【Solution】

We need at least $2 \times 11 = 22$ keys. Since $3 \times 7 = 21$, three staff members are not enough. With four staff members, two can hold the keys to rooms 1 to 7 while the other two can hold the keys to rooms 5 to 11.

Answer : (B)

21. If the first digit after the decimal point of a number is 4 or less, the number is rounded down, but if it is 5 or more, the number is rounded up. When 4 times a positive integer is divided by 100, the result after rounding is 18. When 9 times the same integer is divided by 100, the result after rounding is 42. What is this integer?

【Solution】

The integer times 4 is greater than 1749 but less than 1850. The integer times 9 is greater than 4149 but less than 4250. Hence it is greater than $4149 \div 9 = 461$ but less than $1850 \div 4 = 462\frac{1}{2}$. The correct response is 462.

Answer : 462

22. The sum of the three digits of a positive integer is 13. When this integer is subtracted from the one obtained by writing its digits in reverse order, the difference is 297. What is the maximum value of this integer?

【Solution】

The new number is approximately 300 more than the original number. Thus the units digit of the original number should be 3 more than the hundreds digit. Since the digit sum is 13, the largest such number is 508, and indeed $805 - 508 = 297$. The correct response is 508.

Answer : 508

23. A 10 cm by 18 cm piece of paper is folded twice into a 10 cm by 4.5 cm stack of thickness 4, as shown in Figure 1. Eight 1 cm by 3 cm holes, two of which are adjacent, are cut from the stack, as shown in Figure 2. When the stack is unfolded, as shown in Figure 3, what is the area, in cm^2 , of this piece of punctured paper?

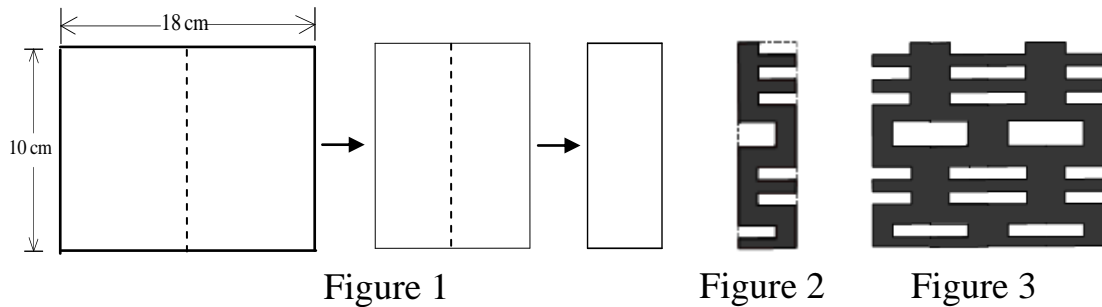

【Solution】

The original area of the piece of paper is $10 \times 18 = 180 \text{ cm}^2$. From each layer, the area removed is $8 \times 3 \times 1 = 24 \text{ cm}^2$. Since there are 4 layers in the stack, the total area removed is $4 \times 24 = 96 \text{ cm}^2$. The area remaining is therefore $180 - 96 = 84 \text{ cm}^2$. The correct response is 084.

Answer : 084

24. The diagram shows a 5 by 5 chessboard and an L-shaped piece which covers exactly 4 squares of the chessboard. It may be rotated or reflected. In how many ways can be it placed on the chessboard covering exactly 4 squares?

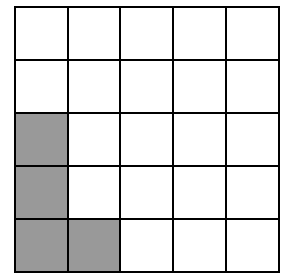

【Solution】

There are 8 different orientations for the piece. In the orientation given, it can be shifted 1 or 2 squares up or 1, 2 or 3 squares to the right. Hence the number of placements of the piece in this orientation is $(2+1) \times (3+1) = 12$. By symmetry, the total number of placements is $8 \times 12 = 96$. The correct response is 096.

Answer : 096

25. In an election between three candidates, they are supported respectively by 10, 35 and 15 of the first 60 voters. 40 more votes are to be cast, each for one of the three candidates. In how many ways can the candidate currently with 10 supporters become the uncontested winner?

【Solution】

After 60 votes have been cast, in order to be the uncontested winner, our favourite candidate must receive at least 26 of the last 40 votes. Then he does not have to worry about the third candidate. In the remaining $40 - 26 = 14$ votes, he must have at least as many votes as his only rival. The total number of distributions of up to 14 votes between them is $1 + 2 + 3 + \dots + 15 = 120$. Of these, 8 ways result in a tie. Half of the remaining $120 - 8 = 112$ ways are in his favour, so that there are $8 + 112 \div 2 = 64$ ways overall. The correct response is 064.

Answer : 064