

注意：

允許學生個人、非營利性的圖書館或公立學校合理使用本基金會網站所提供之各項試題及其解答。可直接下載而不須申請。

重版、系統地複製或大量重製這些資料的任何部分，必須獲得財團法人臺北市九章數學教育基金會的授權許可。

申請此項授權請電郵 ccmp@seed.net.tw

Notice:

Individual students, nonprofit libraries, or schools are permitted to make fair use of the papers and its solutions. Republication, systematic copying, or multiple reproduction of any part of this material is permitted only under license from the Chiuchang Mathematics Foundation.

Requests for such permission should be made by e-mailing Mr. Wen-Hsien SUN ccmp@seed.net.tw

AUSTRALIAN MATHEMATICS COMPETITION

AN ACTIVITY OF THE AUSTRALIAN MATHEMATICS TRUST

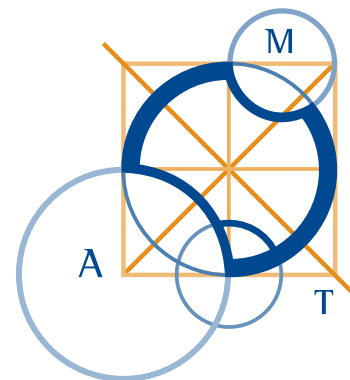

THURSDAY 31 JULY 2008

INTERMEDIATE DIVISION COMPETITION PAPER

AUSTRALIAN SCHOOL YEARS 9 AND 10
TIME ALLOWED: 75 MINUTES

INSTRUCTIONS AND INFORMATION

GENERAL

1. Do not open the booklet until told to do so by your teacher.
2. NO calculators, slide rules, log tables, maths stencils, mobile phones or other calculating aids are permitted. Scribbling paper, graph paper, ruler and compasses are permitted, but are not essential.
3. Diagrams are NOT drawn to scale. They are intended only as aids.
4. There are 25 multiple-choice questions, each with 5 possible answers given and 5 questions that require a whole number between 0 and 999. The questions generally get harder as you work through the paper. There is no penalty for an incorrect response.
5. This is a competition not a test; do not expect to answer all questions. You are only competing against your own year in your own State or Region so different years doing the same paper are not compared.
6. Read the instructions on the **Answer Sheet** carefully. Ensure your name, school name and school year are filled in. It is your responsibility that the Answer Sheet is correctly coded.
7. When your teacher gives the signal, begin working on the problems.

THE ANSWER SHEET

1. Use only lead pencil.
2. Record your answers on the reverse of the Answer Sheet (not on the question paper) by FULLY colouring the circle matching your answer.
3. Your Answer Sheet will be read by a machine. The machine will see all markings even if they are in the wrong places, so please be careful not to doodle or write anything extra on the Answer Sheet. If you want to change an answer or remove any marks, use a plastic eraser and be sure to remove all marks and smudges.

INTEGRITY OF THE COMPETITION

The AMC reserves the right to re-examine students before deciding whether to grant official status to their score status to their score.

7. A rectangle has an area of 72 square centimetres and the length is twice the width. The perimeter, in centimetres, of the rectangle is

- (A) 34 (B) 36 (C) 42 (D) 48 (E) 54

8. What percentage of y is x ?

- (A) $\frac{y}{x}$ (B) $\frac{x}{100}$ (C) $\frac{x}{y}$ (D) $\frac{100y}{x}$ (E) $\frac{100x}{y}$

9. In the diagram, triangles PQR and LMN are both equilateral and $\angle QSM = 20^\circ$. What is the value of x ?

- (A) 70 (B) 80 (C) 90
(D) 100 (E) 110

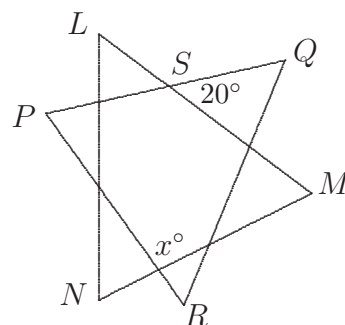

10. When 1000^{2008} is written as a numeral, the number of digits written is

- (A) 2009 (B) 6024 (C) 6025 (D) 8032 (E) 2012

Questions 11 to 20, 4 marks each

11. Anne designs the dart board shown, where she scores P points in the centre circle, Q points in the next ring and R points in the outer ring. She throws three darts in each turn. In her first turn, she gets two darts in ring Q and one in ring R and scores 10 points. In her second turn, she gets two in circle P and one in ring R and scores 22 points.

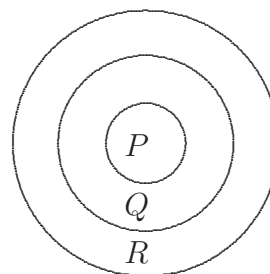

In her next turn, she gets one dart in each of the regions. How many points does she score?

- (A) 12 (B) 13 (C) 15 (D) 16 (E) 18

12. How many different positive numbers are equal to the product of two odd one-digit numbers?

- (A) 25 (B) 15 (C) 14 (D) 13 (E) 11

13. Points A, B, C, D and E are nodes of a square grid as shown. Which of these five points forms an isosceles triangle with the other two vertices at X and Y ?

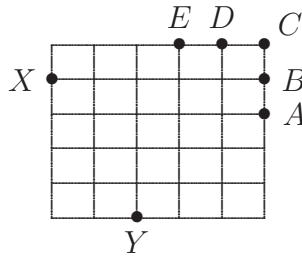

- (A) A (B) B (C) C (D) D (E) E

14. A Fibonacci die has the numbers 1, 1, 2, 3, 5 and 8 on it. Two such dice are thrown. What is the probability that the number on one die is larger than the number on the other?

- (A) $\frac{1}{2}$ (B) $\frac{5}{9}$ (C) $\frac{2}{3}$ (D) $\frac{5}{6}$ (E) $\frac{7}{9}$

15. A fishtank with base 100 cm by 200 cm and depth 100 cm contains water to a depth of 50 cm. A solid metal rectangular prism with dimensions 80 cm by 100 cm by 60 cm is then submerged in the tank with an 80 cm by 100 cm face on the bottom.

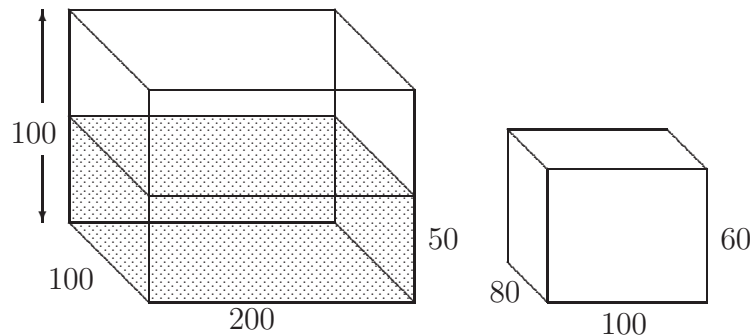

The depth of water, in centimetres, above the prism is then

- (A) 12 (B) 14 (C) 16 (D) 18 (E) 20

Questions 21 to 25, 5 marks each

- 21.** Farmer Taylor of Burra has two tanks. Water from the roof of his farmhouse is collected in a 100 kL tank and water from the roof of his barn is collected in a 25 kL tank. The collecting area of his farmhouse roof is 200 square metres while that of his barn is 80 square metres. Currently, there are 35 kL in the farmhouse tank and 13 kL in the barn tank.

Rain is forecast and he wants to collect as much water as possible. He should:

- (A) empty the barn tank into the farmhouse tank
 (B) fill the barn tank from the farmhouse tank
 (C) pump 10 kL from the farmhouse tank into the barn tank
 (D) pump 10 kL from the barn tank into the farmhouse tank
 (E) do nothing
-

- 22.** If the tens digit of a perfect square is 7, how many possible values can its units digit have?

- (A) 0 (B) 1 (C) 2 (D) 3 (E) 4
-

- 23.** Twenty-five different positive integers add to 2008. What is the largest value that the least of them can have?

- (A) 65 (B) 66 (C) 67 (D) 68 (E) 69
-

- 24.** PQR is an equilateral triangle. The point U is the mid-point of PR . Points T and S divide QP and QR in the ratio 1 : 2. The point of intersection of PS , RT and QU is X . If the area of $\triangle QSX$ is 1 square unit, what is the area, in square units, of $\triangle PQR$?

- (A) 6 (B) 8 (C) 9
 (D) 12 (E) 18

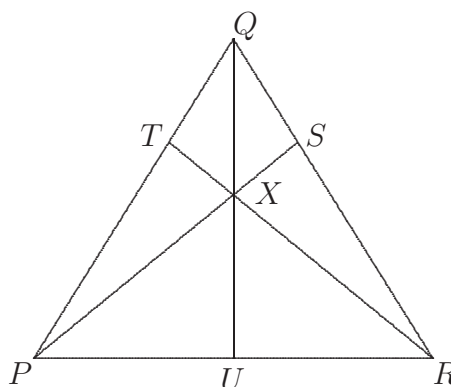

- 25.** A two-digit number n has the property that the sum of the digits of n is the same as the sum of the digits of $6n$. How many such numbers are there?

- (A) 0 (B) 3 (C) 4 (D) 8 (E) 10
-

For questions 26 to 30, shade the answer as an integer from 0 to 999 in the space provided on the answer sheet.

Question 26 is 6 marks, question 27 is 7 marks, question 28 is 8 marks, question 29 is 9 marks and question 30 is 10 marks.

26. In the diagram,
 $\angle OPQ = \angle OQR = \angle ORS = 90^\circ$.
 $OP = 4$ cm, $PQ = 3$ cm and $QR = 12$ cm.
 The perimeter of the pentagon $OPQRS$ is 188 cm.
 What is the area, in square centimetres, of the pentagon $OPQRS$?

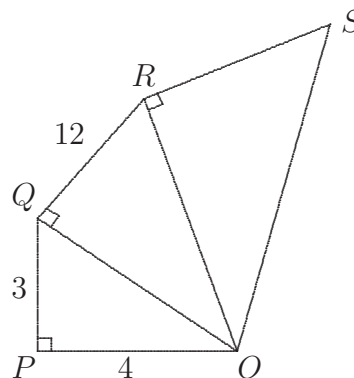

27. A rectangular prism 6 cm by 3 cm by 3 cm is made up by stacking 1 cm by 1 cm by 1 cm cubes. How many rectangular prisms, including cubes, are there whose vertices are vertices of the cubes, and whose edges are parallel to the edges of the original rectangular prism? (Rectangular prisms with the same dimensions but in different positions are different.)

28. The number 2008! (factorial 2008) means the product of all the integers 1, 2, 3, 4, ..., 2007, 2008. With how many zeroes does 2008! end?

29. Let us call a sum of integers *cool* if the first and last terms are 1 and each term differs from its neighbours by at most 1. For example, the sum $1 + 2 + 3 + 4 + 3 + 2 + 3 + 3 + 3 + 2 + 3 + 3 + 2 + 1$ is cool.
 How many terms does it take to write 2008 as a cool sum if we use no more terms than necessary?

30. All the vertices of a 15-gon, not necessarily regular, lie on the circumference of a circle and the centre of this circle is inside the 15-gon. What is the largest possible number of obtuse-angled triangles where the vertices of each triangle are vertices of the 15-gon?