

注意：

允許學生個人、非營利性的圖書館或公立學校合理使用本基金會網站所提供之各項試題及其解答。可直接下載而不須申請。

重版、系統地複製或大量重製這些資料的任何部分，必須獲得財團法人臺北市九章數學教育基金會的授權許可。

申請此項授權請電郵 [ccmp@seed.net.tw](mailto:ccmp@seed.net.tw)

**Notice:**

**Individual students, nonprofit libraries, or schools are permitted to make fair use of the papers and its solutions. Republication, systematic copying, or multiple reproduction of any part of this material is permitted only under license from the Chiuchang Mathematics Foundation.**

**Requests for such permission should be made by e-mailing Mr. Wen-Hsien SUN [ccmp@seed.net.tw](mailto:ccmp@seed.net.tw)**

# AUSTRALIAN MATHEMATICS COMPETITION

AN ACTIVITY OF THE AUSTRALIAN MATHEMATICS TRUST

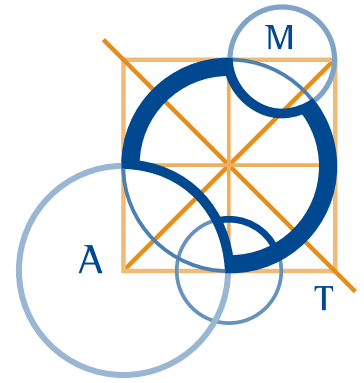

THURSDAY 31 JULY 2008

## SENIOR DIVISION COMPETITION PAPER

AUSTRALIAN SCHOOL YEARS 11 AND 12

TIME ALLOWED: 75 MINUTES

### INSTRUCTIONS AND INFORMATION

#### GENERAL

1. Do not open the booklet until told to do so by your teacher.
2. NO calculators, slide rules, log tables, maths stencils, mobile phones or other calculating aids are permitted. Scribbling paper, graph paper, ruler and compasses are permitted, but are not essential.
3. Diagrams are NOT drawn to scale. They are intended only as aids.
4. There are 25 multiple-choice questions, each with 5 possible answers given and 5 questions that require a whole number between 0 and 999. The questions generally get harder as you work through the paper. There is no penalty for an incorrect response.
5. This is a competition not a test; do not expect to answer all questions. You are only competing against your own year in your own State or Region so different years doing the same paper are not compared.
6. Read the instructions on the **Answer Sheet** carefully. Ensure your name, school name and school year are filled in. It is your responsibility that the Answer Sheet is correctly coded.
7. When your teacher gives the signal, begin working on the problems.

#### THE ANSWER SHEET

1. Use only lead pencil.
2. Record your answers on the reverse of the Answer Sheet (not on the question paper) by FULLY colouring the circle matching your answer.
3. Your Answer Sheet will be read by a machine. The machine will see all markings even if they are in the wrong places, so please be careful not to doodle or write anything extra on the Answer Sheet. If you want to change an answer or remove any marks, use a plastic eraser and be sure to remove all marks and smudges.

#### INTEGRITY OF THE COMPETITION

The AMC reserves the right to re-examine students before deciding whether to grant official status to their score.

---

## Senior Division

---

### Questions 1 to 10, 3 marks each

1. The value of  $8002 - 2008$  is

- (A) 200            (B) 8            (C) 6006            (D) 1060            (E) 5994
- 

2. The difference between  $\frac{1}{20}$  and  $\frac{2}{10}$  is

- (A) 0            (B)  $\frac{1}{10}$             (C)  $\frac{3}{5}$             (D)  $\frac{3}{10}$             (E)  $\frac{3}{20}$
- 

3. In the diagram,  $x$  equals

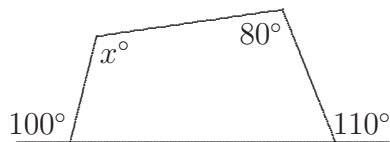

- (A) 100            (B) 110            (C) 120            (D) 130            (E) 140
- 

4. The value of  $\frac{200 \times 8}{200 \div 8}$  is

- (A) 1            (B) 8            (C) 16            (D) 64            (E) 200
- 

5. The smallest value that  $x^2 - 4x + 3$  can have is

- (A)  $-1$             (B)  $-3$             (C) 1            (D) 3            (E) 2
- 

6. \$3 is shared between two people. One gets 50 cents more than the other. The ratio of the larger share to the smaller share is

- (A) 6 : 1            (B) 7 : 5            (C) 4 : 3            (D) 5 : 3            (E) 7 : 4
-

7. When  $1000^{2008}$  is written as a numeral, the number of digits written is  
 (A) 2009      (B) 6024      (C) 6025      (D) 8032      (E) 2012
- 

8. A semicircle is drawn on one side of an equilateral triangle. The ratio of the area of the semicircle to the area of the triangle is

- (A)  $1 : 1$       (B)  $\pi : 2\sqrt{3}$       (C)  $\pi : \sqrt{3}$   
 (D)  $\sqrt{3} : \pi$       (E)  $3 : \pi$

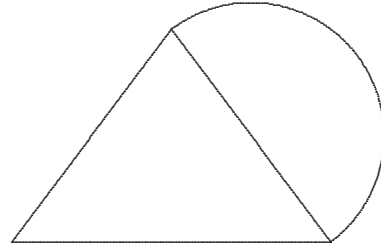

9. Given that  $\cos x = 0.5$  and  $0^\circ < x < 90^\circ$ , which of the following has the greatest value?

- (A)  $\cos^2 x$       (B)  $\cos x$       (C) 0.75      (D)  $\sin x$       (E)  $\tan x$
- 

10. A fishtank with base 100 cm by 200 cm and depth 100 cm contains water to a depth of 50 cm. A solid metal rectangular prism with dimensions 80 cm by 100 cm by 60 cm is then submerged in the tank with an 80 cm by 100 cm face on the bottom.

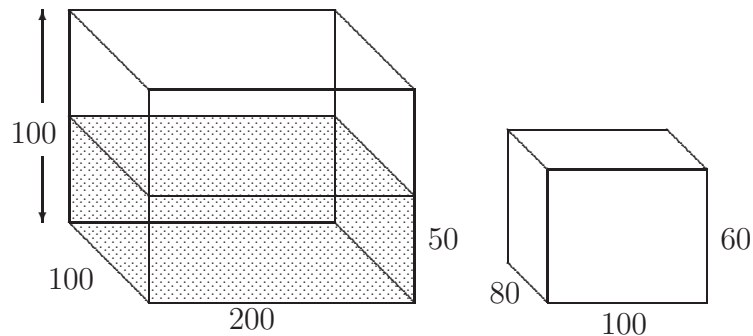

The depth of water, in centimetres, above the prism is then

- (A) 12      (B) 14      (C) 16      (D) 18      (E) 20
- 

**Questions 11 to 20, 4 marks each**

11. Which of the following numbers is the largest?

- (A)  $2^{500}$       (B)  $3^{400}$       (C)  $4^{300}$       (D)  $5^{200}$       (E)  $6^{100}$
- 

12. A normal die is thrown 100 times. The sum of the numbers obtained will most likely be

- (A) 200      (B) 250      (C) 300      (D) 350      (E) 400
-

13. What is the smallest whole number which gives a square number when multiplied by 2008?
- (A) 2                      (B) 4                      (C) 251                      (D) 502                      (E) 2008

14. A cross is made up of five squares, each with side length 1 unit. Two cuts are made, the first from  $X$  to  $Y$  and the second from  $Z$  to  $T$ , so that  $ZTX$  is a right angle. The three pieces are then arranged to form a rectangle.

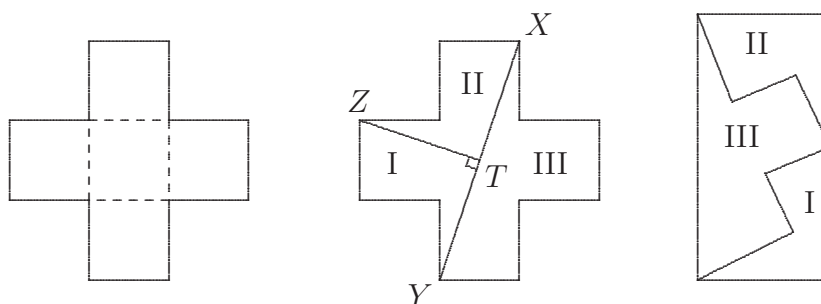

What is the ratio of the length to the width of the rectangle?

- (A) 3 : 1                      (B)  $\sqrt{10} : 1$                       (C) 2 : 1                      (D)  $2\sqrt{3} : 1$                       (E) 5 : 2
- 
15. A function is said to be a toggle function on  $(p, q, r)$  if  $f(p) = q$ ,  $f(q) = r$  and  $f(r) = p$ .  
The function  $f(x) = ax^2 + bx + c$  is a toggle function on  $(1, 2, 3)$ .  
What is the value of  $c$ ?
- (A) -2                      (B) 0                      (C) 3                      (D) 9                      (E) 14

16. Two conical rollers with perpendicular axes touch on a line that is  $30^\circ$  to the axis of the smaller roller and  $60^\circ$  to the axis of the larger roller. If the larger roller makes 1 revolution per second and there is no slipping, how many revolutions per second does the smaller roller make?

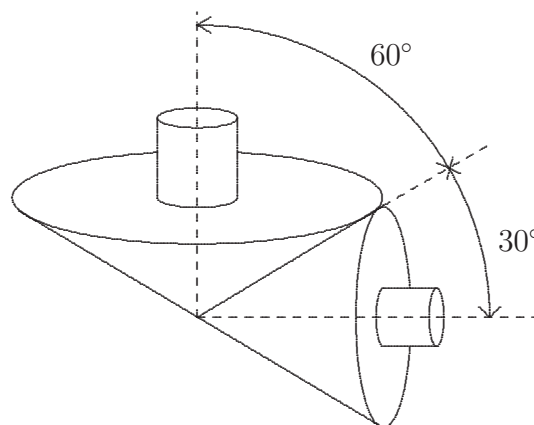

- (A)  $\frac{1}{2}$                       (B) 1                      (C)  $\sqrt{2}$   
(D)  $\sqrt{3}$                       (E) 2

17. Consider the set  $X = \{1, 2, 3, 4, 5, 6\}$ .

How many subsets of  $X$ , with at least one element, do not contain two consecutive integers?

- (A) 16                      (B) 18                      (C) 20                      (D) 21                      (E) 24

18. Farmer Taylor of Burra has two tanks. Water from the roof of his farmhouse is collected in a 100 kL tank and water from the roof of his barn is collected in a 25 kL tank. The collecting area of his farmhouse roof is 200 square metres while that of his barn is 80 square metres. Currently, there are 35 kL in the farmhouse tank and 13 kL in the barn tank.

Rain is forecast and he wants to collect as much water as possible. He should:

- (A) empty the barn tank into the farmhouse tank  
 (B) fill the barn tank from the farmhouse tank  
 (C) pump 10 kL from the farmhouse tank into the barn tank  
 (D) pump 10 kL from the barn tank into the farmhouse tank  
 (E) do nothing

19. A sequence  $\{u_1, u_2, \dots, u_n\}$  of real numbers is defined by

$$\begin{aligned} u_1 &= \sqrt{2}, & u_2 &= \pi, \\ u_n &= u_{n-1} - u_{n-2} & \text{for } n &\geq 3. \end{aligned}$$

What is  $u_{2008}$ ?

- (A)  $-\sqrt{2}$       (B)  $2008(\sqrt{2} - 2008\pi)$       (C)  $1003\sqrt{2} - 1004\pi$       (D)  $\pi$       (E)  $\sqrt{2}$

20. In the diagram,  $RU$  is equal in length to  $ST$ . What is the ratio of the area of  $\triangle QRU$  to the area of  $\triangle QST$ ?

- (A)  $\sqrt{3} : 1$       (B)  $2 : 1$       (C)  $\sqrt{6} : 1$   
 (D)  $\sqrt{3} : 2$       (E)  $\sqrt{6} : 2$

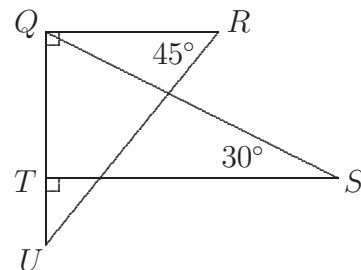

**Questions 21 to 25, 5 marks each**

21.  $P, Q, R, S$  and  $T$  are consecutive vertices of a regular polygon. When extended, the lines  $PQ$  and  $TS$  meet at  $U$  with  $\angle QUS = 160^\circ$ . How many sides has the polygon?

- (A) 36                      (B) 42                      (C) 48                      (D) 52                      (E) 54

22. How many numbers from 1, 2, 3, 4, ..., 2008 have a cubic number other than 1 as a factor?

- (A) 346                      (B) 336                      (C) 347                      (D) 251                      (E) 393

23. The numbers 828 and 313 are 3-digit palindromes where  $828 - 313 = 515$ , which is also a palindrome. How many pairs  $(a, b)$  of 3-digit palindromes are there with  $a > b$  and with  $a - b$  also a 3-digit palindrome?

- (A) 1972                      (B) 1980                      (C) 1988                      (D) 1996                      (E) 2008

24. The centres of all faces of a cube are joined to form an octahedron. The centres of all faces of this octahedron are now joined to form a smaller cube. What is the ratio of an edge of the smaller cube to an edge of the original cube?

- (A)  $1 : \sqrt{2}$                       (B)  $1 : \sqrt{3}$                       (C)  $1 : 2$                       (D)  $1 : 3$                       (E)  $1 : 4$

25. In the figure, all line segments are parallel to one of the sides of the equilateral triangle  $PQR$  which has side length 1 unit. How long should  $PX$  be to maximise the smallest of the ten areas defined?

- (A)  $\frac{1}{3}$                       (B)  $\frac{4 - \sqrt{2}}{14}$                       (C)  $\frac{1}{4}$   
 (D)  $\frac{1}{5}$                       (E)  $\frac{1}{\sqrt{10}}$

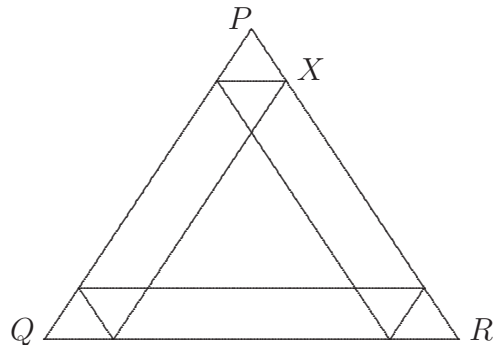

For questions 26 to 30, shade the answer as an integer from 0 to 999 in the space provided on the answer sheet.

Question 26 is 6 marks, question 27 is 7 marks, question 28 is 8 marks, question 29 is 9 marks and question 30 is 10 marks.

26. All possible straight lines joining the vertices of a cube with mid-points of its edges are drawn. At how many points inside the cube do two or more of these lines meet?

- 27.** Let us call a sum of integers *cool* if the first and last terms are 1 and each term differs from its neighbours by at most 1. For example, the sum  $1 + 2 + 3 + 4 + 3 + 2 + 3 + 3 + 3 + 2 + 3 + 3 + 2 + 1$  is cool.  
How many terms does it take to write 2008 as a cool sum if we use no more terms than necessary?
- 

- 28.** The positive integers  $x$  and  $y$  satisfy

$$3x^2 - 8y^2 + 3x^2y^2 = 2008.$$

What is the value of  $xy$ ?

---

- 29.** A point  $O$  is inside an equilateral triangle  $PQR$  and the perpendiculars  $OL$ ,  $OM$  and  $ON$  are drawn to the sides  $PQ$ ,  $QR$  and  $RP$  respectively.

The ratios of lengths of the perpendiculars  $OL : OM : ON$  is  $1 : 2 : 3$ .

If  $\frac{\text{area of } LONP}{\text{area of } \triangle PQR} = \frac{a}{b}$ , where  $a$  and  $b$  are

integers with no common factors, what is the value of  $a + b$ ?

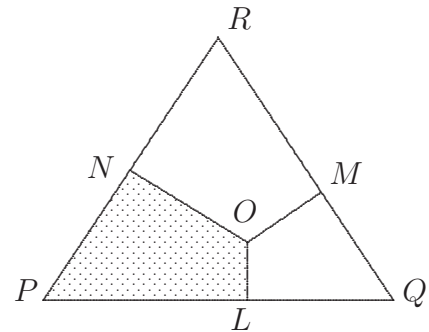

- 30.** What is the smallest value that

$$\sqrt{49 + a^2 - 7\sqrt{2}a} + \sqrt{a^2 + b^2 - \sqrt{2}ab} + \sqrt{50 + b^2 - 10b}$$

can have for positive real numbers  $a$  and  $b$ ?

---